

SWP

Screw Wash Press in Stainless Steel

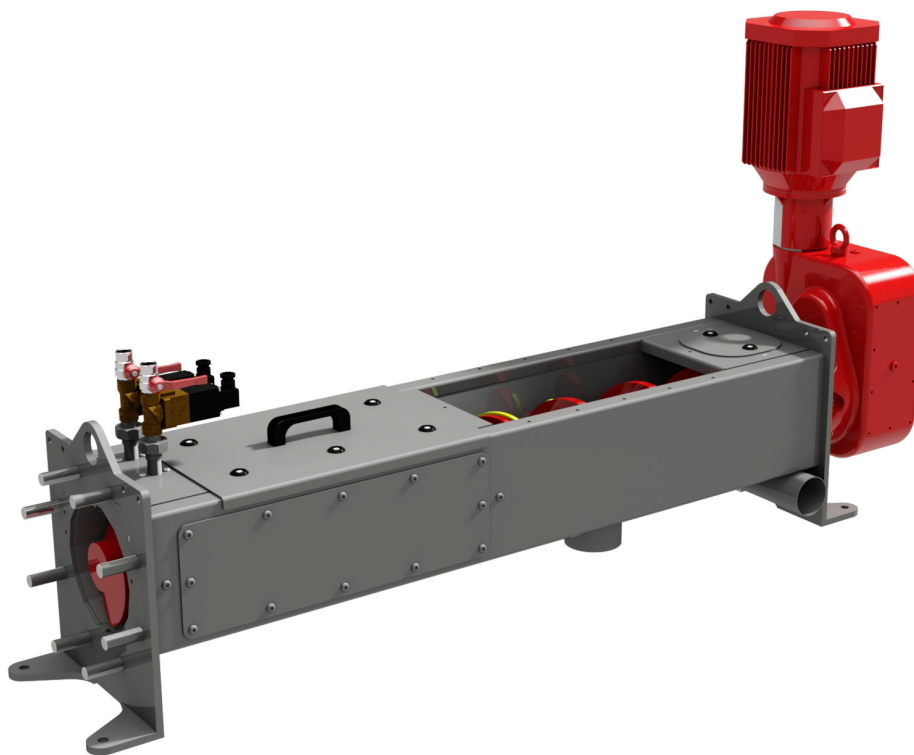

Main areas of use and features

- Washing fecals out of screenings
- Dissolvable organic contents are brought back into the treatment process
- Major weight and volume reduction of screenings
- Minimization of odour problems and disposal costs
- SWP achieves DS content of 40-60%
- High finish guarantees a long life time

SWP SCREW WASH PRESS

Area of use

Meva SWP is well suited for both smaller and larger waste water treatment plants. It is a compact and cost efficient unit, which has proven good functionality due to its simple and functional design.

Combined with a Meva fine screen, the result is an optimal screenings unit. Feeding to the Meva SWP can also be done via coarse screens, sieves or transportation equipment such as spiral or belt conveyors.

Advantages

Return of washed out organic contents to the treatment process and increase of the DS content of the screenings. The combination of Meva Screw Wash Press and Meva Counter Pressure Screw results in a product optimal for incineration.

Due to the increased use of fine screens, the amount of screenings separated from waste water is constantly increasing. The amount of screenings leads to increased odour problems and disposal costs.

Using Meva SWP to wash the fecal content and reducing the screenings volume is advantageous for both environmental and economical reasons.



Function

Screenings are pushed forward by a slowly rotating screw. Wash water is added in the wash/press zone, where dissolved materials and water are pressed out and brought back into the waste water treatment process. The washed and pressed screenings are discharged by a CPS or pipe system.

The working cycle is adjusted by the control system with regard to the composition of the screenings. The retention time in the press can be prolonged by replacing the press pipe with a counter pressure system. This will result in more efficient washing and higher DS content.

Meva SWP is designed with double troughs making it very “torque resistant” for heavy operations with screenings of high DS content. The high “torque resistance” enables the SWP to be delivered with a large inlet opening. Further, the double trough allows for the inner section to be fully perforated and, thereby, allowing maximal dewatering.

The screw runs close to the inner trough, which results in high drainage. A robust axial bearing and a worm gear absorb the forces from the press. The press zone is easily accessible through a hatch.

SWP is mainly manufactured in stainless steel. The screw and wear parts are manufactured in highly durable steel.

Meva Screw Wash Press SWP:

- Washing fecals out of screenings
- Dissolvable organic content are brought back to the treatment process
- Major weight and volume reduction of screenings
- Minimization of odour problems and disposal costs
- SWP achieves DS content of 40-60%
- High finish guarantees a long life time



Washed and dewatered screenings



Washing and dewatering



Meva Screw Wash Press - Compact and easy to operate

Technical Specification

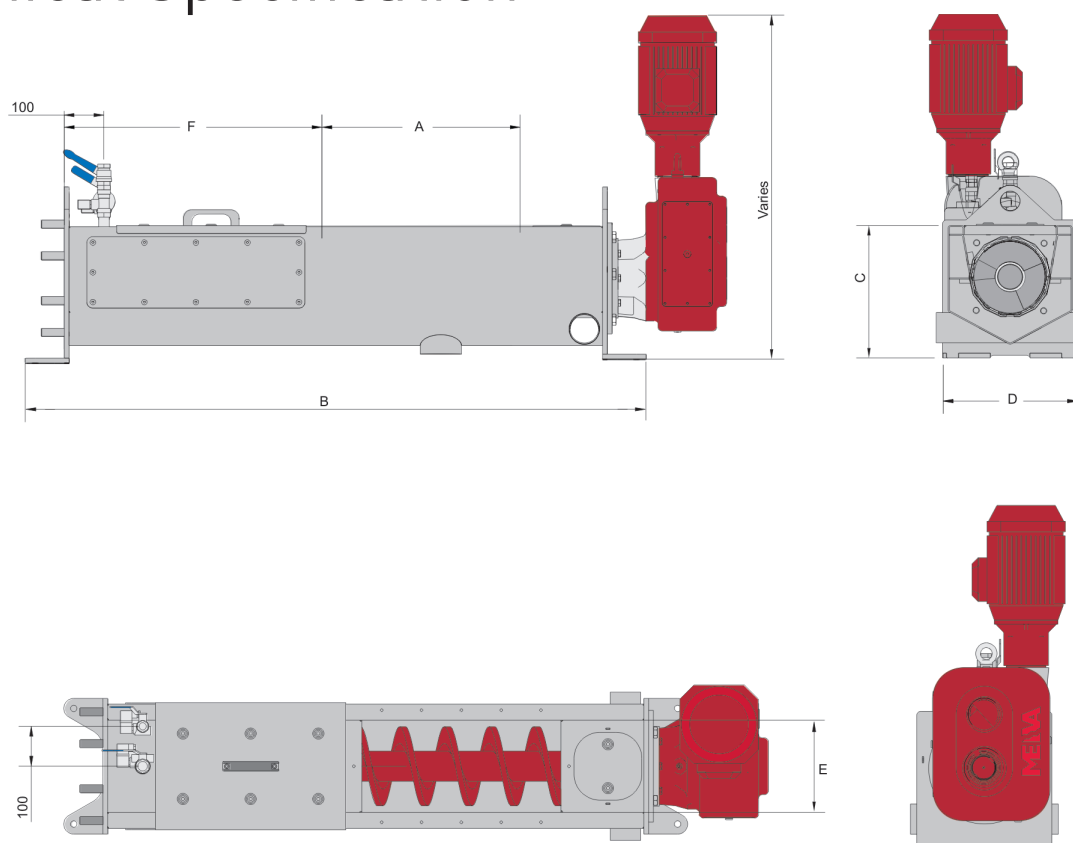

	SWP 15	SWP 20	SWP 25	SWP 30	SWP 40
Capacity (m ³ /h)*	0.5-1	up to 2	up to 3	up to 5	up to 8
Connecting flange	DN 150	DN 200	DN 250	DN 300	DN 400
(A) Inlet opening	300-600	300-3000	300-3000	300-3000	400-1200
(B) Total length	1010-1310	1370-4070	1375-4075	1450-4150	1760-2560
(C) Height	290	330	380	430	635
(D) Width	280	340	405	450	600
(E) Inlet width	200	230	300	350	450
(F) Wash zone	460	650	650	725	900

Measurements in millimeter.

* Wet material, capacity depending on degree of filling.

