

SA

Grit Classifier in Stainless Steel

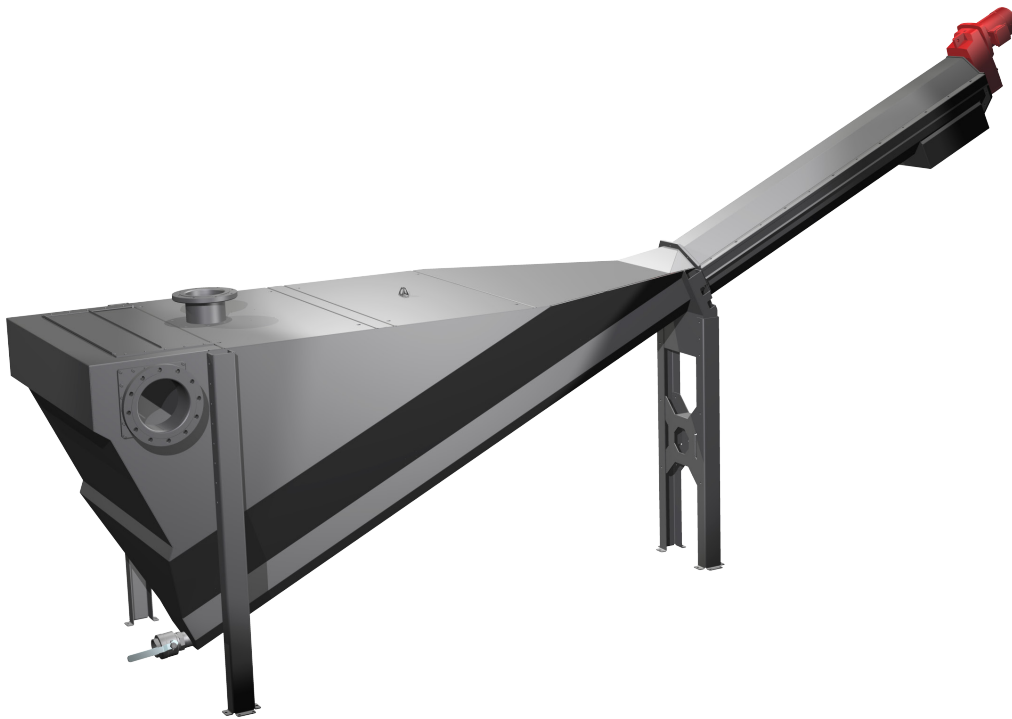

Main areas of use and features

- Grit separator with capacity up to 35l/s
- Heavy-duty, very robust design
- Improved, service and maintenance friendly design
- Fully capsuled, ventilation connection available
- Optional washing system for reduction of organic contents
- Longofill available, for odour free installation
- Flange connected conveyor sections
- High finish guarantees a long life time

SA GRIT CLASSIFIER

Area of use

The Meva sand separator provides the perfect solution for slurries and wet mixtures as it traps sedimentary particles and dewateres them, before discharging them. It is indispensable for grit handling in sewage treatment plants and for sand, bark and metal pollutants in paper mills.

This new grit classifier from Nordic Water is a natural development based on years of experience from installations worldwide.

Function

Incoming slurry is led through the inlet into the sedimentation tank, where a continuous sedimentation process takes place. Water overflows through the outlet while sand settles at the bottom, where it is conveyed and dewatered by the spiral conveyor.

The design comes with improved inspection and cleaning possibilities, and a wear bar system that is easily replaceable without welding. The conveyor section can be delivered in various lengths and removed from the tank for transportation. The conveyor can be fitted with a washing system, to decrease the amount of organics in the dewatered grit.

