

OCS

Odour Control System in Stainless Steel



Main areas of use and features

- Efficient removal of odour
- Superior carbon capacity/life time
- 100% maintenance free
- Performs well at high humidity
- Small footprint

OCS ODOUR CONTROL SYSTEM

Area of use

Carbon adsorption is a safe and efficient way to remove odours from air. Adsorbing carbon removes several organic and inorganic odour substances from the process air at waste water treatment plants. Hydrogen sulphide and ammonia are cost effectively and efficiently removed. The filter takes little space and the only moveable parts are placed in the fan. Meva OCS is an excellent alternative to chemical wet scrubbing and biotechnology.

Meva OCS contains catalytic impregnated activated carbon, distinguishing it from traditional carbon filters with untreated or only catalytic carbon. The advantage of catalytic carbon is that the carbon is not consumed when an odour substance, such as hydrogen sulphide, is adsorbed to the surface. Instead, the hydrogen sulphide is transformed through a catalytic oxidation without reacting with the carbon. The oxidizing substance is oxygen from the incoming air. This catalytic reaction is the same for Meva OCS, but unlike a carbon that is only catalytic the impregnated carbon of the OCS does not require regular washing and it doesn't leave an acidic by-product. The impregnation leads to an additional chemical reaction, resulting in a much higher capacity and a residue of only water and salt.

Function

The OCS unit can be connected both before and after the fan. The polluted air is led in at the bottom, passes through the carbon bed and is led out at the top of the OCS unit. The carbon bed is designed with regard to the substances which are to be removed from the air, and the desired flow. The OCS unit does not contain moveable parts and does not need any maintenance. The carbon should not be washed. When the carbon is used it should be sent for destruction.



Carbon types are chosen and combined depending on the pollution.



Why carbon filter?

Except for the unpleasant smell of rotten eggs, hydrogen sulphide is a toxic gas. Good ventilation and punctual suction at strategic places is crucial for creating a good working environment at the plants. However, the air is not cleaned and the problem is merely moved outside, where staff and adjacent residences might be bothered by the smell.

Meva OCS can be installed in existing ventilations or in new buildings to eliminate the mentioned problems. The unit does not require any maintenance or service and reference products have been operating for more than twelve years, before the carbon needed to be exchanged.



Insulated and heated, for outdoor installation. Here together with Zickert Cover - Z6000.

Meva Odour Control System OCS:

- Efficient removal of odour
- Superior carbon capacity/life time
- 100% maintenance free
- Performs well at high humidity
- Small footprint



Removes odour substances up to 99%



Meva Odour Control System OCS



Odour removal for pump stations close to other buildings

Technical Specification

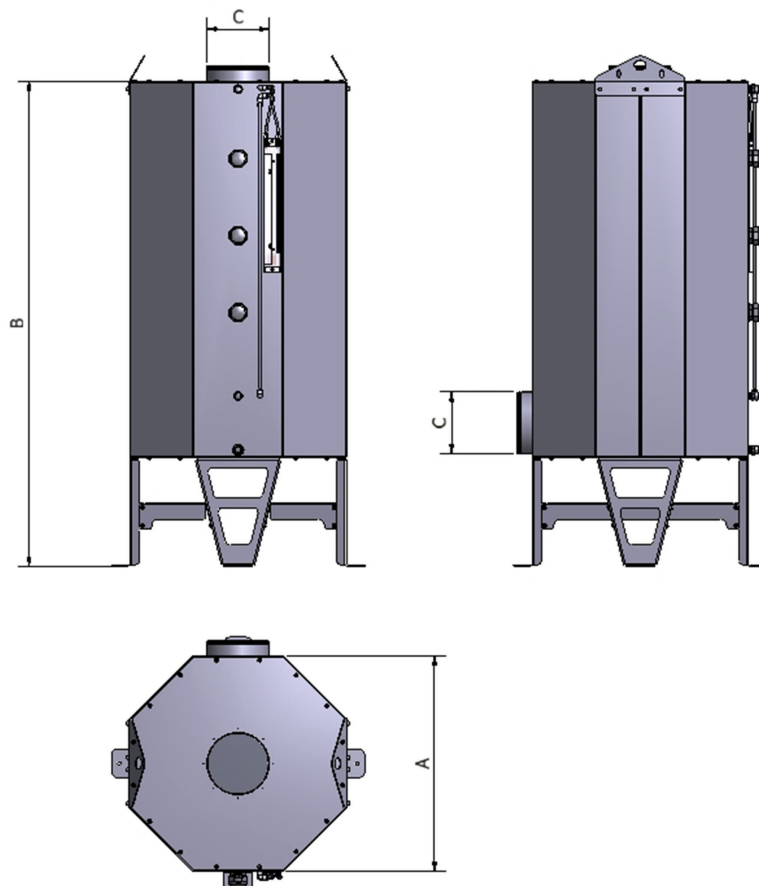

A selection of units:

	OCS 300	OCS 500	OCS 700	OCS 1000	OCS 1500
Diameter (A)	300	500	700	1000	1500
Height (B)	1200	1400	1400	1500	1600
Inlet / Outlet (C)	100	160	200	315	400
Carbon (kg)	44	119	238	487	933
Max capacity (m ³ /h)	100	290	570	1150	2600

Measurements in millimeter.

